

ANGLE 1

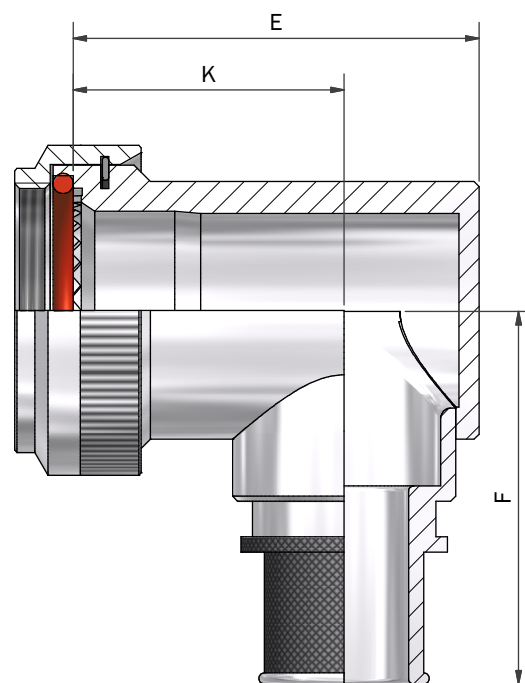

ANGLE 3

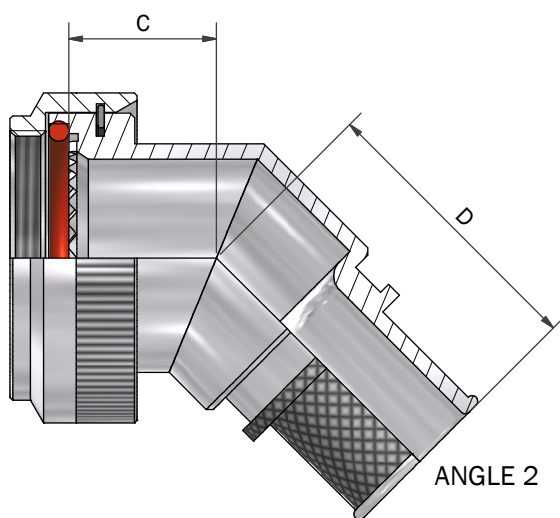
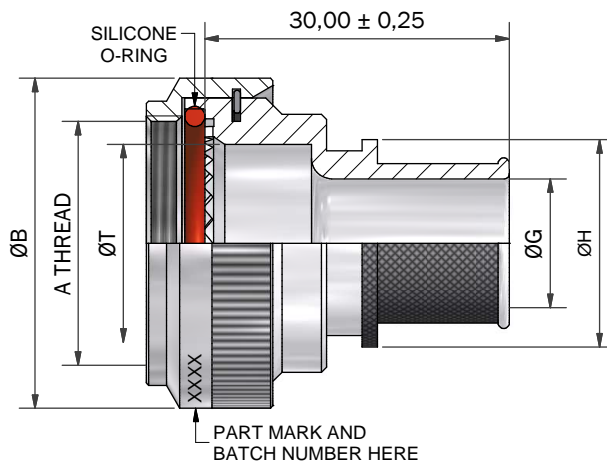
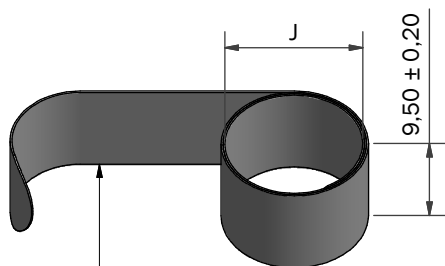

CONSTANT FORCE SPRING (TABLE 3)

DRAWN	J.CLARK	DATE	07/09/2010	3RD ANGLE PROJECTION NOT TO SCALE	POLAMCO WESTON LOCK LOWER BRISTOL ROAD BATH BA2 1EP	PAGE 1 OF 3	UNLESS OTHERWISE SPECIFIED ALL DIMENSIONS IN MILLIMETRES
SALES APPR							
DESIGN APPR	K.SHEP	DATE	21/02/2008	THIS DRAWING IS COPYRIGHT AND THE PROPERTY OF POLAMCO LTD. IT MUST NOT BE COPIED, USED FOR MANUFACTURE OR OTHERWISE DISCLOSED WITHOUT PRIOR WRITTEN CONSENT OF THE COMPANY.	ASSY USED ON: MIL-DTL-38999 SERIES III & IV TITLE:	MATERIAL ALUMINIUM ALLOY 6262	NCAGE CODE U5792
QUAL APPR							
ISSUE 3	DCR 3969						
WEIGHT	GENERAL TOL LINEAR +/-0.1MM ANGULAR +/- 1°			PART NUMBER:	91H SERIES	DRAWING NO:	P10743

TABLE 1

SHELL SIZE	A THREAD	ØB MAX	ØT MIN	C MAX	D MAX	E MAX	F MAX	K ±0,5
09	M12 x 1.0	18,0	6,7	13,1	25,7	25,7	30,5	17,5
11	M15 x 1.0	21,0	10,2	13,9	26,9	26,7	32,2	17,5
13	M18 x 1.0	24,5	13,5	14,5	27,3	31,2	33,7	20,0
15	M22 x 1.0	29,0	16,2	15,5	28,2	37,2	35,2	24,5
17	M25 x 1.0	32,5	19,4	16,1	29,0	40,2	36,9	26,7
19	M28 x 1.0	35,5	21,8	16,8	29,3	44,7	38,5	27,0
21	M31 x 1.0	37,0	25,1	17,1	30,1	49,2	40,1	30,5
23	M34 x 1.0	40,0	28,2	17,7	30,5	51,7	41,6	31,5
25	M37 x 1.0	43,5	31,4	18,4	31,4	53,2	43,1	28,5

TABLE 2

ENTRY SIZE	ØG MIN	ØH MAX	SPRING REF
03	4,7	13,9	HE050
04	6,3	13,9	HE050
05	7,9	15,5	HE100
06	9,5	17,2	HE100
07	11,1	18,7	HE100
08	12,7	20,3	HE200
09	14,2	21,9	HE200
10	15,8	23,5	HE200
11	17,4	25,1	HE200
12	19,0	26,7	HE300
13	20,6	28,3	HE300
14	22,2	29,9	HE300
15	23,8	31,5	HE300
16	25,4	33,1	HE300
17	27,0	34,7	HE400
18	28,6	36,3	HE400
19	30,2	37,9	HE400
20	31,8	39,5	HE400
21	33,3	41,1	HE400
22	35,0	42,7	HE400
23	36,5	44,3	HE400
24	38,1	45,9	HE400

TABLE 3

SPRING REF	J MAX (UNCONSTRAINED)
HE 050	7,5
HE 100	8,0
HE 200	12,8
HE 300	17,9
HE 400	21,8

TABLE 4

CODE	FINISH
C	ELECTROLESS NICKEL
B	CADMIUM OLIVE DRAB OVER ELECTROLESS NICKEL
ZB	ZINC COBALT OLIVE DRAB OVER ELECTROLESS NICKEL

LIST NOT EXHAUSTIVE, SEE PLATING TABLE FOR OTHER OPTIONS

91H1-17-08-1-C-HE200

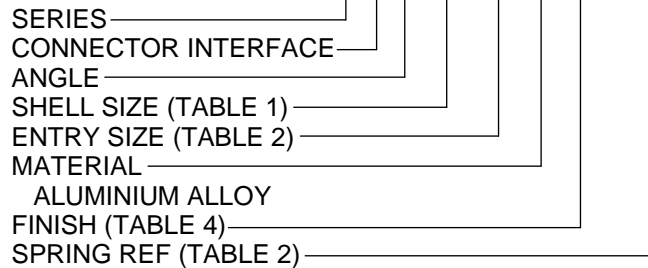

DRAWN SALES APPR	J.CLARK	DATE 07/09/2010	 3RD ANGLE PROJECTION NOT TO SCALE	 WESTON LOCK LOWER BRISTOL ROAD BATH BA2 1EP	PAGE 2 OF 3	UNLESS OTHERWISE SPECIFIED ALL DIMENSIONS IN MILLIMETRES
DESIGN APPR QUAL APPR	K.SHEP	21/02/2008				
ISSUE 3	DCR 3969		THIS DRAWING IS COPYRIGHT AND THE PROPERTY OF POLAMCO LTD IT MUST NOT BE COPIED, USED FOR MANUFACTURE OR OTHERWISE DISCLOSED WITHOUT PRIOR WRITTEN CONSENT OF THE COMPANY.	ASSY USED ON: MIL-DTL-38999 SERIES III & IV		MATERIAL ALUMINIUM ALLOY 6262 NCAGE CODE U5792
WEIGHT	GENERAL TOL LINEAR +/-0.1MM ANGULAR +/- 1°			TITLE: SPRING ADAPTOR PART NUMBER: 91H SERIES		